PLAQUE

MFM18240

UNDERWATER
LIGHT



Operating Instructions

ASTEL
MARINE

CONTENTS

Preface.....	3
Features.....	3
Precautions.....	3
Controls and Connectors.....	4
Underwater Light PLAQUE MFM18240.....	4
Power Supply Unit MPS06800.....	5
Installation.....	6
Underwater Light PLAQUE MFM18240.....	6
Power Supply Unit MPS06800.....	7
Appearance.....	9
Technical Specifications.....	9
Warranty.....	10
Declaration of Conformity.....	11



PREFACE

The PLAQUE series underwater lights are designed to use the latest LED lighting technology for flush-mount installation where the most important are low-profile casings to avoid high water resistance and quality materials to assure very reliability installation and operation.

All the models are available in aluminium bronze casings. The lighting is available in white, blue or green colors or three-color. All the models are designed with 18 power LEDs and suitable power supply units.

FEATURES

- Aluminium Bronze or Anodized Aluminium Casing
- 18 Power LEDs Design
- White, Blue, Green or Three-Color Lighting
- Tempered Glass Optical Window
- High-Efficiency Lens
- Low Power Consumption
- Over-Temperature Protection
- Simple Installation
- Remote Control (optional)

PRECAUTIONS

- The underwater light has to be installed and used in accordance with the instructions of this manual only.
- The power supply has to be disconnected before installation.
- The underwater light is recommended to be installed around 0.2 m below the waterline for the best illumination and to avoid overheating.
- Do not try to install or remove the underwater light while the vessel is in the water.
- The optical window has to be cleaned by a soft brush or cloth. Avoid using any abrasive or chemical cleaner on the optical window.
- Avoid installing the power supply unit in extremely hot places and near appliances generating strong magnetic fields.
- Do turn power off immediately and refer servicing to qualified service personnel if the underwater light does not operate normally following the operating instructions.

CONTROLS AND CONNECTORS

Underwater Light PLAQUE MFM18240

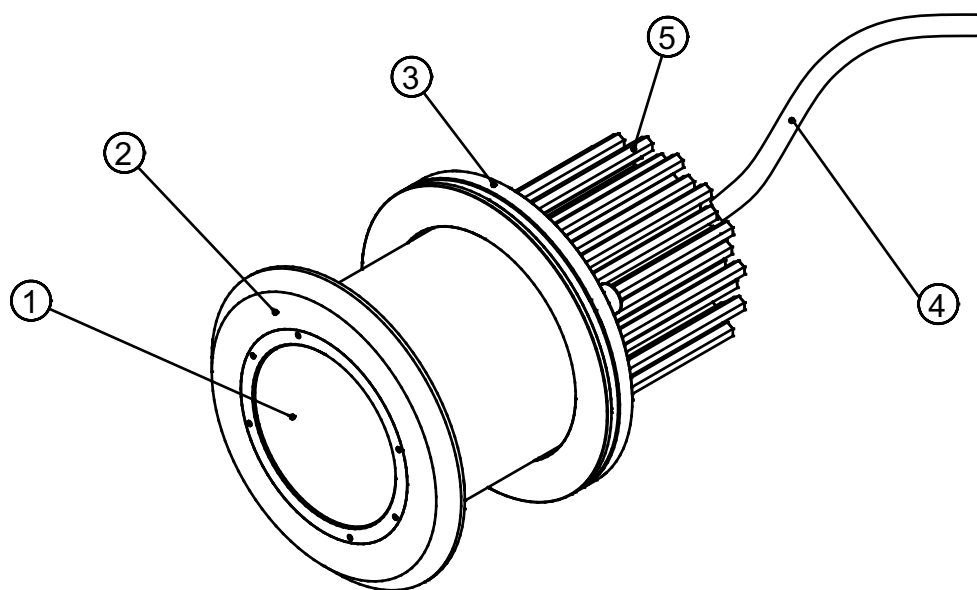

(1) Optical window

The 6 mm depth tempered glass optical window.

(2) Underwater light casing

Aluminium bronze casing with fixing holes and cable gland.

(3) Fixing assembly

The fixing nut, washer and screws to fix the underwater light on the hull.

(4) Cable

The 8-pole multi-core cable to connect the power supply unit.

(5) Heat sink

The aluminium heat sink to enable properly temperature stability of the underwater light.

Power Supply Unit MPS06800

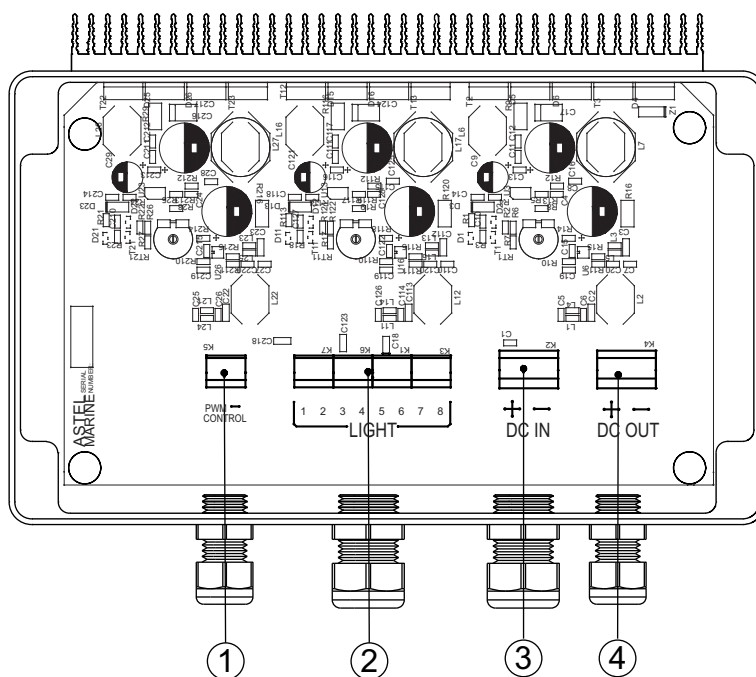

(1) CONTROL

Terminal-block connector to connect optional remote control unit or switch.

(2) LIGHT

Terminal-block connector to connect the LED underwater light using 8-pole multi-core cable.

(3) DC IN

Terminal-block connector to connect 12-24Vdc power supply.

(4) DC OUT

Terminal-block connector to connect to the DC IN connector of another power supply unit.

INSTALLATION

The underwater light kit consists of the following components:

- Underwater Light PLAQUE MFM18240
- Power Supply Unit MPS06800
- Washer
- Fixing nut with 4 screws M8 and bonding screw M4
- 2 x cable gland M12
- Operating Instructions with Declaration of Conformity and Warranty conditions

Underwater Light PLAQUE MFM18240

The PLAQUE MFM18240 has to be installed on a flat surface of the hull of the vessel.

Do not try to install the underwater light while the vessel is in the water.

When the installation is finished briefly test the underwater light prior to launching the vessel.

The installation have to be realized by a qualified personnel.

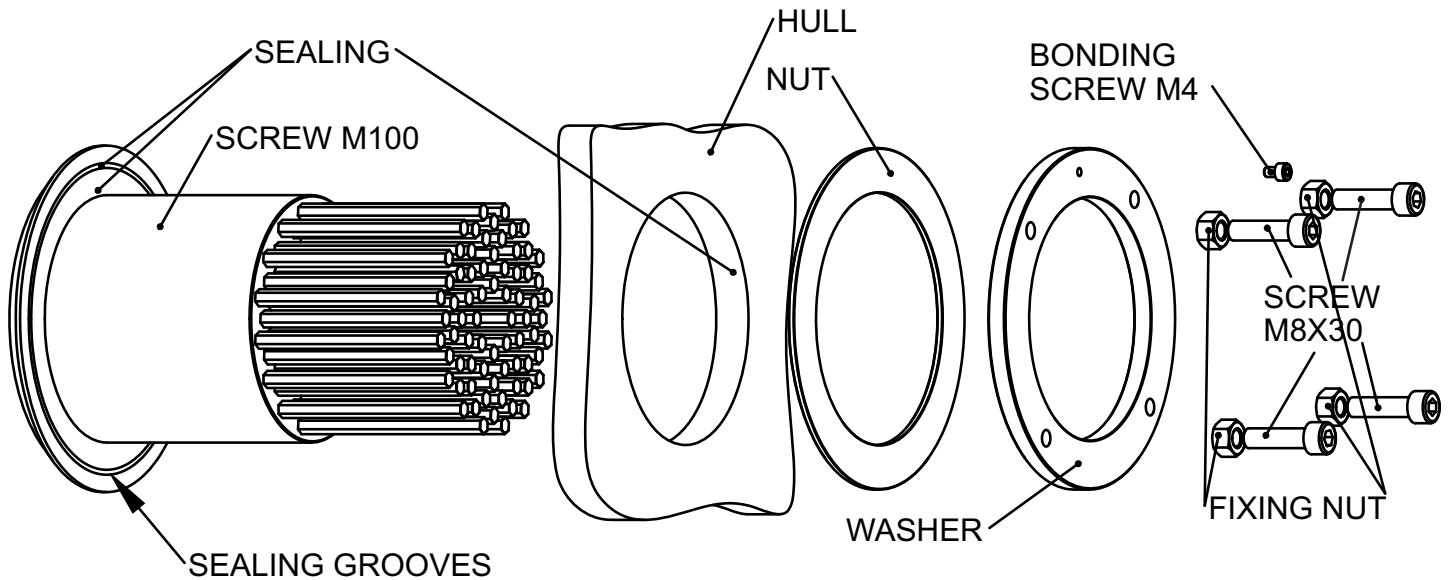

Note:

- **Avoid using the underwater light out of the water for more than 5 minutes. The underwater light is protected by a temperature sensor against over-heating. When the temperature of the underwater light exceeds 60°C the power supply unit starts to reduce the current of the LEDs. If the temperature of the underwater light exceeds 90°C the underwater light is automatically switched off.**

Hull preparation

The underwater light is recommended to be installed around 0.2 m below the waterline for the best illumination and to avoid over-heating.

To fix the underwater light the diameter of a hole drilled through the hull has to be 102 mm.

Sealing

Before inserting the underwater light through the hole the sealant has to be used into the grooves and has to be added to the exposed inner hole surface from the inside of the hull under the washer.

The sealant can be on silicon basis but the best solution is two-component polymer sealant.

Fixing

The underwater light has to be inserted through the hole from outside of the hull and has to be fixed by the help of the fixing nut with 4 screws M8 and washer.

Note:

- **To install the underwater light on the steel hull it is highly recommended to use the optional isolation board (not included) between the hull and underwater light casing to prevent galvanic corrosion.**

Note:

- **Do not overtighten the screws as this can result in hull or underwater light damage.**

Bonding

The underwater light has to be connected to the vessels bonding and cathodic protection using a pre-tinned wire a minimum of 8 AWG (8.36 mm²) with green insulation or green with a yellow stripe. The wire has to be connected to the underwater light by the help of the bonding screw M4 located on the fixing nut.

Note:

- **It is highly recommended to paint the entire underwater casing exposed to the water with anti-foul paint.**
- **The optical window is protected with foil which has to be removed after anti-fouling process.**

Power Supply Unit MPS06800

The MPS06800 has to be installed near the underwater light inside of the vessel. Avoid the installation in extremely hot places and near appliances generating strong magnetic fields. An extension cable can be used in case of longer distance between the underwater light and the power supply unit but with suitable length and thickness. The installation have to be realized by a qualified personnel.

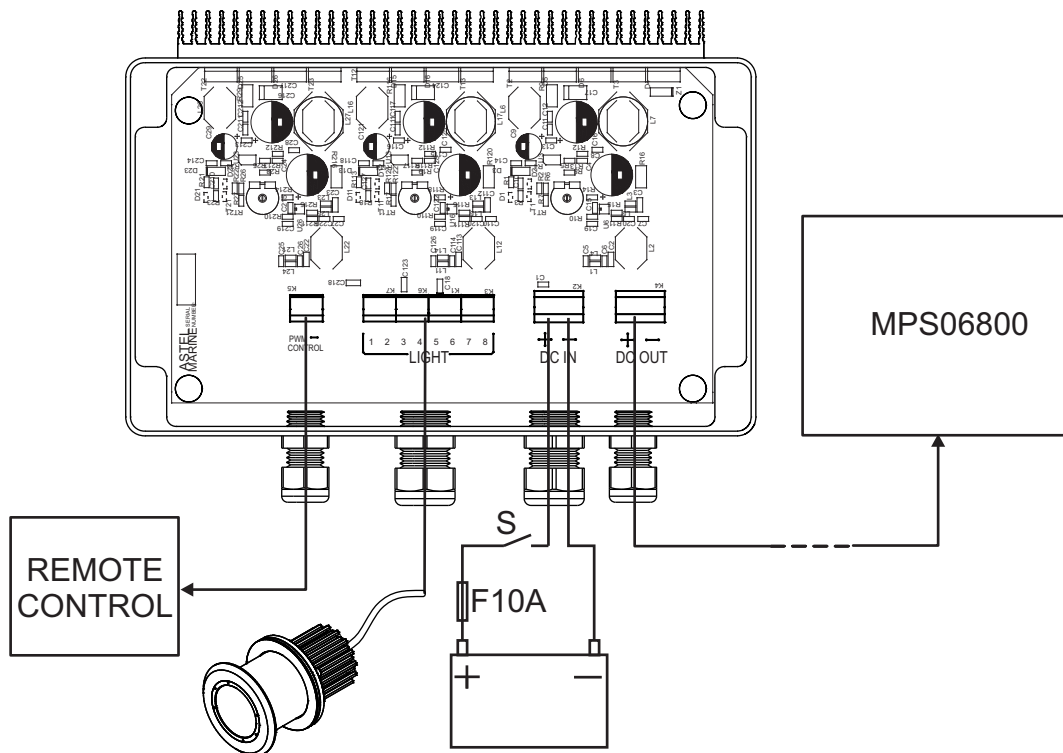

Note:

- **The main DC power supply of the vessel has to be switched off before installation.**

Power supply connection

The power supply has to be connected through the switch (not included) and protected by a fuse (not included) to the DC IN terminal-block connector with correct polarity. The power supply voltage has to be from 10 - 30Vdc.

A power supply unit of another underwater light can be connected to the DC OUT terminal-block connector.

Note:

- ***Only one additional power supply unit of the same model number can be connected to the DC OUT terminal-block connector and suitable power supply cable should be used. The appurtenant cap should be removed from the casing and enclosed cable gland M12 should be inserted.***

Underwater light connection

The underwater light has to be connected to the LIGHT terminal-block connector as described in the table below:

MPS06800 terminal-block connector LIGHT	PLAQUE MFM18240 wire colour	FUNCTION
1	Brown	LED1+
2	Blue	LED1-
3	Orange	LED2+
4	Violette	LED2-
5	Yellow	LED3+
6	Green	LED3-
7	Red	Temperature sensor +
8	Black	Temperature sensor -

Remote control connection

Remote control (optional) can be connected to the CONTROL terminal-block connector to turn-on and turn-off and to control the luminosity of the underwater light.

To remotely turn-on and turn-off the underwater light the simple switch (not included) can be used and connected to the CONTROL terminal-block connector by a 2-pole signal cable (not included).

Note:

- ***To connect the 2-pole signal cable the appurtenant cap should be removed from the casing and enclosed cable gland M12 should be inserted.***

Note:

- ***If remote control is not used for normal operation the both contacts of CONTROL terminal-block connector has to be bridged.***

APPEARANCE

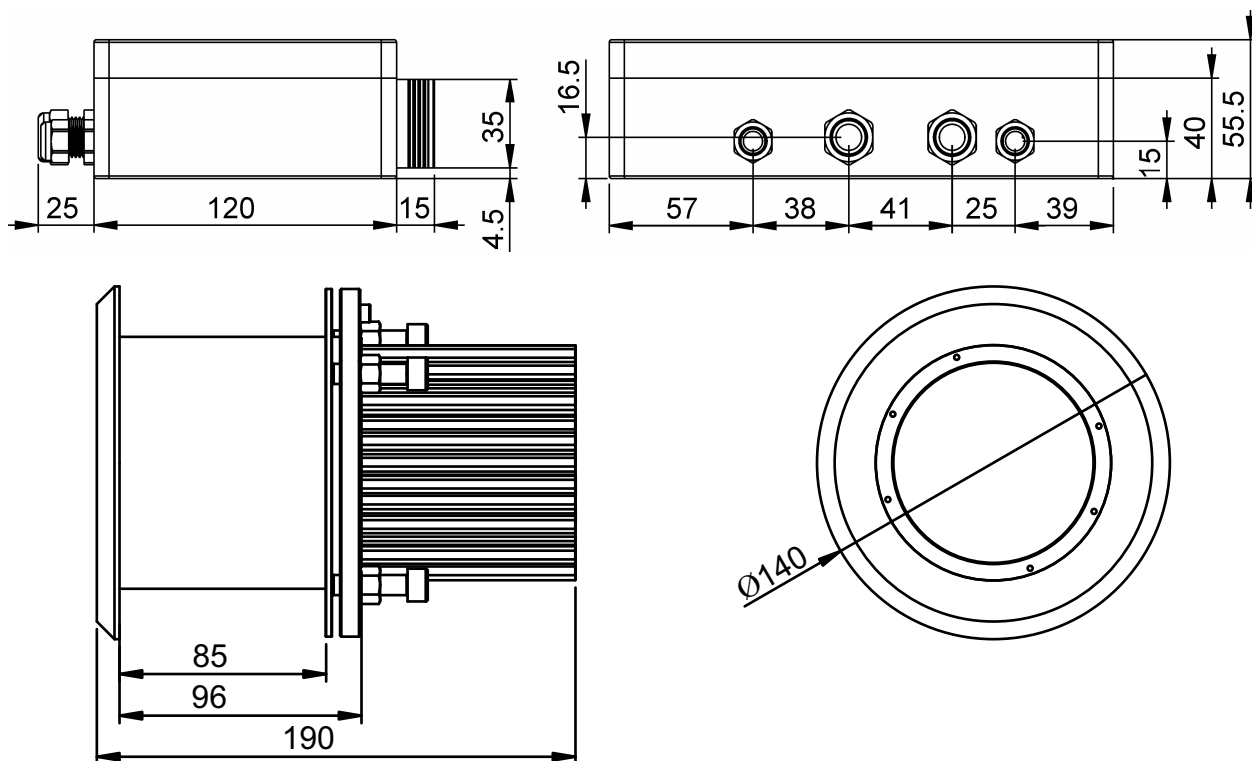

TECHNICAL SPECIFICATIONS

LED Underwater Light PLAQUE MFM18240

Power requirement	3x800 mA
Lens angle	50°
Optical window	6 mm depth tempered glass
Luminous flux	3.900 lm
White color temperature	10.000 K
Operating temperature	-10°C - +50°C
Casing	Aluminium bronze (AB2)
Protection	IP 68
Dimensions	Ø140x190mm
Weight	6.7 kg

Power Supply Unit MPS06800

Input voltage	12-24 Vdc
Consumption	max. 5.4 Adc/12 Vdc or 2.5 Adc/24 Vdc
Operating temperature	-10°C - +50°C
Casing	Polycarbonate
Protection	IP 65
Dimensions	200x160x55.5mm
Weight	0.6 kg

Design and specifications subject to change without notice.

WARRANTY

1. The equipment manufactured by ASTEL d.o.o. is warranted to be free from defects in workmanship and materials under normal use and service.
2. This Warranty is in effect for of two years from the date of purchase by the user. Proof of purchase must be included, to establish that it is inside the warranty period.
3. This Warranty is transferrable and covers the product for the specified time period.
4. In case any part of the equipment proves to be defective, other than those parts excluded in paragraph 5 below, the owner should do the following:
 - (a) prepare a detailed written statement of the nature and circumstances of the defect, to the best of the Owner's knowledge, including the date of purchase, the place of purchase, the name and address of the installer, and the Purchaser's name, address and telephone number;
 - (b) the Owner should return the defective part or unit along with the statement referenced in the preceding paragraph to the warrantor, ASTEL d.o.o., or an authorized distributor, postage/shipping prepaid and at the expense of the Purchaser;
 - (c) if upon the Warrantor's or authorized distributor's examination, the defect is determined to result from defective material or workmanship, the equipment will be repaired or replaced at the Warrantor's option without charge, and returned to the Purchaser at the Warrantor's expense;
 - (d) no refund of the purchase price will be granted to the Purchaser, unless the Warrantor is unable to remedy the defect after having a reasonable number of opportunities to do so. Prior to refund of the purchase price, Purchaser must submit a statement in writing from a professional boating equipment supplier that the installation instructions of the Operating Instructions manual have been complied with and that the defect remains;
 - (e) warranty service shall be performed only by the Warrantor, or an authorized distributor, and any attempt to remedy the defect by anyone else shall render this warranty void.
5. There shall be no warranty for defects or damages caused by faulty installation or hook-up, abuse or misuse of the equipment including exposure to excessive heat, salt or fresh water spray, or water immersion except for equipment specially designed as waterproof.
6. There shall be no responsibility or liability whatsoever on the part of the Warrantor or its employees and representatives for injury to any person or persons, or damage to property, loss of income or profit, or any other consequential or resulting damage or cost which may be claimed to have been incurred through the use or sale of the equipment, including any possible failure or malfunction of the equipment, or part thereof.
7. The Warrantor assumes no liability for incidental or consequential damages of any kind including damages arising from collision with other vessels or objects.

DECLARATION OF CONFORMITY

according to IEC Guide 22 and EN 45014

Manufacturer's Name: ASTEL, Podjetje za projektiranje, proizvodnjo in trgovino, d.o.o.

Manufacturer's Address: Dutovlje 138
6221 Dutovlje
Slovenija

declares that the products

Item, Product Name and Model Number: 1. Underwater Light PLAQUE MFM18240 with Power Supply Unit MPS06800

conform to the following Product Specifications:

EMC: EN 55022 (CISPR 22: 1993)
EN 50130-4: 1994

Safety: EN 60950
EN 60529

Supplementary Information:

The products herewith comply with the requirements of the following Directives and carry the CE-marking accordingly:

- the EMC Directive 89/336/EEC
- the Safety Directive 73/23/EEC

ASTEL d.o.o.
Dutovlje 138
6221 Dutovlje
Slovenija

5th December, 2008

ASTEL d.o.o., Dutovlje 138, 6221 Dutovlje, Slovenia
Tel: +386 5 7310771, +386 5 7310772
Fax:+386 5 7310789
E-mail: info@astel-marine.com
Web: www.astel-marine.com